

AX-1255

INSTRUCTIONS



PREFACE - Contents

Contents	3
PREFACE	
Safety Instructions.....	3
Precautions.....	4
Declaration of Conformity.....	5
Supplied Accessories.....	6
Warranty.....	6
SECTION 1 – Quick Install Guide.....	7
SECTION 2 – Introduction	
Features	8
Front Panel	10
Rear Panel	11
SECTION 3 – Installation	
Typical Configuration.....	12
Controller Wiring.....	14
SECTION 4 – Menu Navigation	
User.....	15
System.....	19
SECTION 5 – Web Application	
Monitor and Control.....	22
Configuration.....	24
SECTION 6 – Specifications.....	35
Acknowledgements.....	36

Please visit www.axiumcontrol.com for the latest Information.

Safety Instructions

1. Read these instructions.
2. Keep these instructions.
3. Heed all warnings.
4. Follow all instructions.
5. Do not use this apparatus near water.
6. Clean only with dry cloth.
7. Do not block any ventilation openings. Install in accordance with the manufacturer's instructions.
8. Do not install near any heat sources such as radiators, heat registers, stoves, or other apparatus (including other amplifiers) that produce heat.
9. Use the apparatus only in Moderate climates. (not in tropical climates)
10. Do not defeat the safety purpose of the polarized or grounding type plug. A polarized plug has two blades with one wider than the other, a grounding type plug has two blades, and a third grounding prong, the wide blade or the third grounding prong is provided for your safety. If the provided plug does not fit onto your outlet, consult an electrician for replacement of the obsolete outlet.
11. Protect the power cord from being walked on or pinched particularly at plugs, convenience receptacles, and the point where they exit from the apparatus.
12. Only use attachments / accessories specified by the manufacturer.
13. Unplug this apparatus during lightning storms or when unused for long periods of time.
14. If you install the apparatus in a built-in installation, such as a bookcase or rack, ensure that there is adequate ventilation. Leave 20cm (8") of free space at the top and sides and 10cm (4") at the rear. The rear edge of the shelf or board above the apparatus shall be set 10cm (4") away from the rear panel or wall, creating a flue like gap for warm air to escape. Good airflow is necessary to help ensure proper operation. Not only should you provide enough free space around the unit but also ensure that air can flow freely and escape from the amplifier surroundings. Failure to do so may cause thermal shutdown of the unit, and reduced life expectancy.
15. Refer all servicing to qualified service personnel. Servicing is required when the apparatus has been damaged in any way, such as:
 - When the power supply cord or plug is damaged.
 - If liquid has been spilled, or objects have fallen into the apparatus.
 - If the apparatus has been exposed to rain or water.
 - If the apparatus has been dropped or damaged in any way.
 - If the apparatus does not operate normally by following the instructions. Adjust only those controls that are covered by the operating instructions.
 - When the apparatus exhibits distinct change in performance this indicates a need for a service.



WARNING! Do not expose the apparatus to dripping or splashing.
Do not place objects filled with liquids near the apparatus



AVERTISSEMENT! N'exposez pas l'appareil à des gouttes ou à des éclaboussures.
Ne placez pas d'objets remplis de liquides à proximité de l'appareil.



WARNING! To reduce the risk of fire or electric shock,
Do not expose this apparatus to rain or moisture.



AVERTISSEMENT! Pour réduire le risque d'incendie ou d'électrocution,
n'exposez pas cet appareil à la pluie ou à l'humidité.



WARNING! Never push objects of any kind into the apparatus through openings as they may touch dangerous voltage points or short-circuit parts that could result in fire or electric shock.



AVERTISSEMENT! Ne poussez jamais d'objets de quelque nature que ce soit dans l'appareil à travers des ouvertures car ils pourraient toucher des points de tension dangereux ou des pièces de court-circuit qui pourraient entraîner un incendie ou un choc électrique.



WARNING!
PROTECTING EARTH TERMINAL: The Apparatus must be connected to a mains socket with a protective Earth Connection



AVERTISSEMENT!
PROTECTOIN DE LA BORNE DE MISE à LA TERRE: L'appareil doit être connecté à une prise secteur avec une connexion de terre de protection.



IMPORTANT! The Mains Plug is used as the disconnect device and it shall remain readily operable.



IMPORTANT! La fiche secteur est utilisée comme dispositif de déconnexion et doit rester facilement utilisable.



IMPORTANT! Ensure adequate ventilation. Do not install in a cabinet that is smaller than 60cm (24") wide x 45cm (18") deep x 20cm (8") high. If you do the device may overheat.



IMPORTANT! Assurez une ventilation adéquate. Ne pas installer dans une armoire inférieure à 60 cm (24 po) de large x 45 cm (18 po) de profondeur x 20 cm (8 po) de haut. Si vous le faites, l'appareil peut surchauffer.

Precautions

- 1. AC Fuse** - The AC fuse inside the unit is not user-serviceable. If you cannot turn on the unit, contact the dealer from whom you purchased this unit.
- 2. Care** - Occasionally you should dust the unit all over with a soft cloth. For stubborn stains, use a soft cloth dampened with a weak solution of mild detergent and water. Dry the unit immediately afterwards with a clean cloth. Don't use abrasive cloths, thinners, alcohol, or other chemical solvents, because they may damage the finish or remove the panel lettering.
- 3. Power**
WARNING
BEFORE PLUGGING IN THE UNIT FOR THE FIRST TIME, READ THE FOLLOWING SECTION CAREFULLY.
AC outlet voltages vary from country to country. Make sure that the voltage in your area meets the voltage requirements printed on the unit's rear panel. e.g. 110V - 240V~ 50/60HZ
The power cord is used to disconnect this unit from the AC power source. Make sure that the plug is always readily operable (easily accessible).
If you do not intend to use the unit for an extended period, remove the power cord from the AC outlet.
- 4. Earth** – The unit is defined as Class1 in EN62368 (low voltage directive) and **MUST BE EARTHED**. Connect only to a mains socket outlet with protective earth and only use the power cord supplied.
- 5. Never Touch This Unit with Wet Hands** – Never handle this unit or its power cord while your hands are wet or damp. If water or any other liquid gets inside this unit, have it checked by your Autonomic dealer.
- 6. Handling Notes**
 - If you need to transport this unit, use the original packaging.
 - Do not leave rubber or plastic items on this unit for a long time; they may leave marks on the case.
 - This unit's top and rear panels may get warm after prolonged use. This is normal.
- 7. Speaker Shorts**
Under no circumstances should the speaker output terminals of the unit be short circuited, grounded or connected to another output.



Declaration of Conformity

We declare under our sole responsibility that this product, to which this declaration relates, is in conformity with the following standards: IEC62368_1E, EN55013, EN55020, EN61000-3-2 and EN61000-3-3.
Following the provisions of Low Voltage Directive 2006/95/EC and EMC Directive 2004/108/EC, the EC regulation 1275/2008 and its framework Directive 2009/125/EC for Energy-related Products (ErP).



TÜV Certification

This product has been certified and conforms to UL62368-1: 2019 and certified to CSA C22.2 No. 62368-1-19

For North American Models

FCC interference statement

This device complies with Part 15 of the FCC Rules.

Operation is subject to the following two conditions: (1) This device may not cause harmful interference, and (2) this device must accept any interference received, including interference that may cause undesired operation.



IMPORTANT! Changes or modifications not expressly approved by the party responsible for compliance could void the user's authority to operate the equipment.

NOTE: This equipment has been tested and found to comply with the limits for a Class B digital device, pursuant to Part 15 of the FCC Rules. These limits are designed to provide reasonable protection against harmful interference in a residential installation. This equipment generates, uses, and can radiate radio frequency energy and, if not installed and used in accordance with the instructions, may cause harmful interference to radio communications. However, there is no guarantee that interference will not occur in a particular installation. If this equipment does cause harmful interference to radio or television reception, which can be determined by turning the equipment off and on, the user is encouraged to try to correct the interference by one of the following measures:

- Reorient or relocate the receiving antenna.
- Increase the separation between the equipment and receiver.
- Connect the equipment into an outlet on a circuit different from that to which the receiver is connected.
- Consult the dealer or an experienced radio / TV technician for help.

For Canadian Models

NOTE: THIS CLASS B DIGITAL APPARATUS COMPLIES WITH CANADIAN ICES-003

For models having a power cord with a polarized plug:

CAUTION: TO PREVENT ELECTRIC SHOCK, MATCH WIDE BLADE OF PLUG TO WIDE SLOT FULLY INSERT.

Modèle pour les Candadien

REMARQUE: CET APPAREIL NUMÉRIQUE DE LA CLASSE B EST CONFORME À LA NORME NMB-003 DU CANADA. Sur les modèles don't la fiche est polarisée:

ATTENTION: POUR ÉVITER LES CHOCS ÉLECTRIQUES, INTRODUIRE LA LAME LA PLUS LARGE DE LA FICHE DANS LA BORNE CORRESPONDANTE DE LA PRISE ET POUSSER JUSQU' AU FOND.

RECYCLING:

This product's packaging materials are recyclable and can be reused. Please dispose of any materials in accordance with the local recycling regulations.

When discarding the unit, comply with local rules or regulations.

Batteries should never be thrown away or incinerated but disposed of in accordance with the local regulations concerning battery disposal.

This product and the supplied accessories constitute the applicable product according to the WEEE directive.



PREFACE - Supplied Accessories

Locate the following accessories:

AS3112 Australasian Plug to IEC60320 C13 Socket



VDE CEE 7/7 European Plug Schuko to IEC60320 C13 socket.....



Standard US Plug to IEC60320 C13 socket.....



Rack Ears.....



PREFACE - Warranty

Audio Engineering Ltd warrants its products to be free of material and construction defects. The warranty is for One Year from the date of purchase by the original consumer. Any products returned to either Audio Engineering Ltd or the Axium Distributor and found to be defective within the warranty period will be repaired or replaced at no charge. The warranty does not cover costs relating to installation or removal of the product or consequential damages.

SECTION 1 - Quick Install Guide

Thank you for purchasing an Axiom AX-1255 Multi-Zone Amplifier. Please read this manual thoroughly before making connections and plugging in the unit.

Following the instructions in this manual will enable you to obtain optimum performance and listening enjoyment from your new Multi-Zone Amplifier. Please retain this manual for future reference.

Unpacking / Setup

- Check for damage:
Immediately upon receiving the new AX-1255 Multi-Zone amplifier, inspect the carton for evidence of mishandling during shipment. Then carefully unpack the unit and inspect for damage. Please save the shipping carton and all inner package materials in the event that the AX-1255 needs to be shipped for service or moved to a new location.

IMPORTANT: If the AX-1255 Multi-Zone amplifier has been damaged during shipping, please contact the Axiom supplier immediately.

- Verify that all the accessories have been included, see PREFACE: Supplied accessories.
- Read the entire Instruction Manual.

Installation

- Connect Zone outputs 1 – 6 to speakers, using high quality speaker audio cables, e.g. minimum specification is 16 AWG (1.3mm²) Twin or Quad Audio cable.
 - All Speaker cabling should be home runs, avoid joining or crimping wires.
 - Speaker cabling should be kept at least 300mm (12") away from high voltage house wiring.
 - **Amplifier outputs CANNOT be combined. Do Not connect amplifier outputs together in parallel. The Zone outputs are in 'Bridge' configuration, there are no common ground connections;**
The Left Zone output positive and negative terminals are connected to the Left speaker's Positive and negative terminals respectively.
The Right Zone output positive and negative terminals are connected to the Right speaker's positive and negative terminals respectively.
 - Not suitable for use with a stereo speaker with a joined earth. A single speaker requires 2 independent voice coils – where the voice coils are not internally connected. Use a meter to confirm the negative and positive terminals on the speaker input are not joined.
 - Not suitable for use with transformer volume controls.
- Connect Analog Sources 1 – 4 to source equipment, using good quality RCA cables for the Analog L/R connections, and shielded 75Ω RCA cables for the Coax Digital Audio inputs.
- **Digital Audio Coax and Optical signals must be PCM.**
- Connect the AX-1255 to the local network
- Connect Power cord to unit and then plug into an AC outlet to apply power.
- Use the AX-1255 intuitive front panel LCD GUI and Touch Panel to select Zone, and control the amplifier Standby, Source and Volume.

SECTION 2 – Introduction; Features

Multiple Analog & Digital Audio Sources

Sources 1 – 4 are Analog Stereo,
Sources 5 – 6 are Coax Digital Audio (PCM).
Sources 7 – 8 are Optical Digital Audio (PCM)
Sources 1- 8 have gain adjustment: up to +18dB in 2dB steps, and programmable delay up to 600ms in 5ms steps.

Amplifier Zones

Six separate amplifiers independent yet integrated control.
Each zone has controls for bass, treble, balance, loudness, gain, mono, maximum volume limiting – useful for protecting connected speakers and a 7 band graphic/parametric equaliser
Amplifiers are rated 55 Watts into 8 ohm loads, and 98 Watts into 4 ohm loads with < 1% THD. (Independent LAB tested)

Power On Volume

Each Zone may be set to a specific volume level at Power ON.

Preamplifier Zones

Two separate preamplifiers with up to 2V_{RMS} output level (+6dB gain).
Each zone has controls for bass, treble, balance, loudness, gain, mono and maximum volume limiting. In addition, each zone has a low pass filter that when selected only passes low frequency audio for driving Active Subwoofers. When the low pass filter is selected the Tone and loudness controls are defeated.

Thermal Control

There are two progressive levels of thermal control:
90°C - The amplifier volume is reduced 20dB
100°C - The amplifiers are shut down until the temperature reduces below 80°C.
Care should be taken to ensure adequate ventilation – see “Safety instructions” on page 4.

Preamplifier On Output – 3.5mm Jack

Each Pre-Amplifier zone out has a 12VDC AMP-ON status output via a 3.5mm jack.
The ‘AMP ON’ output is protected against shorts.

96 Zones

There are 96 zones of possible control.
On an AX-1255 amplifier each zone must be different.
Same zone amplifiers are **NOT** possible – use zone linking to achieve same zone functionality.

Zone Linking

A zone may be programmed to link multiple zones. Zone linking ties the source selection together. It may also tie the volume, and standby. This is useful for closely coupled audio areas where it is advantageous to have different volume control but the same source, or the same volume with separate standby control. Zone linking is setup either via the front panel user interface, Web application or ADP program.
A new function called Zone Merging has been added where 2 zones are linked as per a linked zone but only 1 instance appears in the app so if a subwoofer is connected by the preouts and Merged to a main zone there will only be 1 zone instance appear in the app, the subwoofer zone will not appear in the app.

Web Interface / Ethernet, and Keypad / IR control

The AX-1255 amplifier is controlled, monitored and programmed via Ethernet.
An AX-1255 amplifier may also be controlled & monitored using one of six Keypad Controller Port connections, where control is through IR commands sent from a connected Keypad.
There are zone specific IR commands and also global IR commands.
The commands are: ON, OFF, Standby (toggling), Mute, Volume Up, Volume Down, Source Selects, On with Source Specific commands.
The Global commands also include 15 PRESETS labelled A – O which can be renamed by the user. Alarm Enable, Alarm OFF, & 5 minute Sleep.
Axiom provides Interface dependent zone IR commands. The keypad port that an IR command is received on decides which zone is controlled so the same command can be used on any zone. Useful if using the same remote control in multiple zones.

IR Emitter Ports

There are 8 Buffered IR emitter Ports. Ports 1 – 8 have IR routing, and are intended to control specific input source components.

Presets and Paging

There are **15** amplifier presets and preset **two hardwired triggers**. Either can be used. Presets are momentary and cause the amplifier to go to a predetermined setup, i.e. standby, volume & source selection. The hardwires inputs are not limited to calling a preset, they can be used to turn a single zone on/off or all zones on/off. The presets may also be programmed with event scheduling and are used by the alarm clock.

Door Bell

48 KHz 16 Bit PCM stereo sounds may be generated as part of the page preset. Suitable sound files are uploaded to the unit using the Web interface – Preset page.

Real Time Clock

The AX-1255 amplifier is equipped with a real time clock and must have internet access to set and synchronize the time with an internet time server. The amplifier may be set up to function as an Alarm clock, so that at 6.30am in the morning 5 days a week, the master bedroom zone could be made to turn on, select tuner, and go to a specific volume. Multiple Alarms are feasible (max of 15) however the Alarm Enable & OFF commands act upon all programmed Alarms. The Clock automatically compensates for daylight saving.

Power Failure Restoration

After an AC power outage the AX-1255 amplifier restores its settings to the pre-interrupted state. All internal settings are stored in non-volatile memory.

Restore Defaults

The AX-1255 amplifier may be readily set to the default settings. Restoring Defaults clears all memory and resets the zone allocations to the first free 8 zone numbers.

Setup Lockout

Locks access to the System Setup and More menus where installation critical adjustments can be made.
Password = 1396

Firmware Upgradable

The AX-1255 amplifier may be updated with the latest operational firmware using Web Interface Config page, or via Axium Design Portal.

SECTION 2 - Introduction; Front Panel Guide

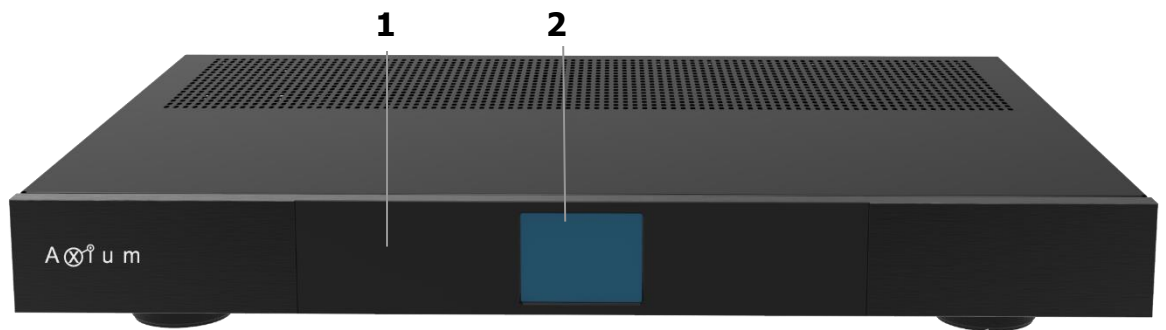

1 Front Panel
Solid Aluminium front Panel

2 2.2" Colour LCD Touch Panel display
LCD Touch Panel display for menu guided control and programming. The display is dimmed to "Off" after 15 minutes of inactivity.

3 Chassis Feet
Set high enough to provide unrestricted air-flow through the chassis for convection cooling.

SECTION 2 - Introduction; Rear Panel Guide

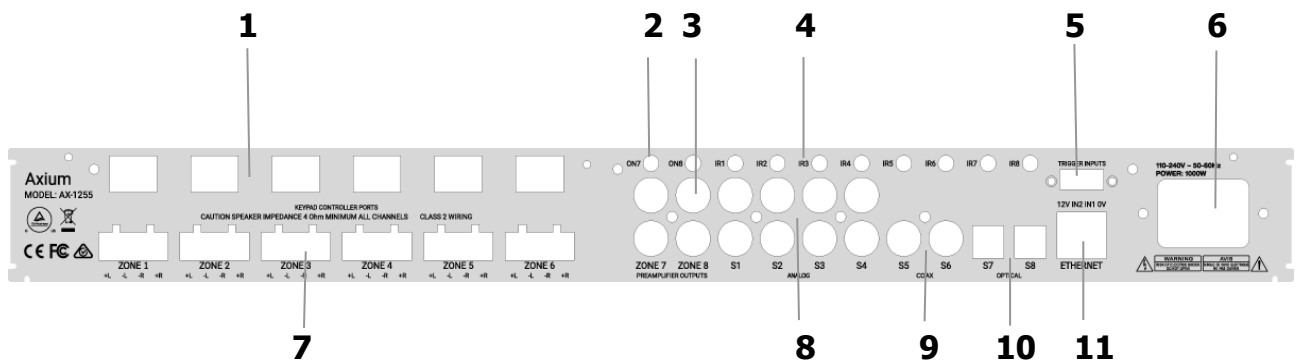

- 1 6 x Keypad Controller Ports (RJ45)**
Assignable Keypad / IR controller inputs
- 2 2 x Preamp 12v triggers**
2 x preamp trigger outputs 3.5mm 12v trigger outs
- 3 2 x Preamp Outputs**
Zone 7 & Zone 8 RCA analogue audio L/R outputs.
- 4 8 x IR (Infrared) Emitter ports**
Source S1 – S8 3.5mm IR out ports
- 5 Trigger Input Terminal**
2 x hardwired trigger inputs, Can be used for doorbells and amp zone on/off. 12v, IN1, IN2, 0V.
- 6 AC power inlet**
IEC Power inlet 110V AC – 240V AC 50 – 60 Hz
- 7 6 x Speaker Terminals**
Plug cable terminal clamp connectors accept 1.5mm² speaker wires.
- 8 4 x Analog Input Terminals**
Analog audio RCA inputs
- 9 2 x Coax Digit in S5 – S6**
Coax Digital RCA input PCM only
- 10 2 x Optical Digital Inputs S7 – S8**
Optical Digital input PCM only
- 11 Ethernet connection**
10/100 Base T primary Ethernet port for Connection to the Home network Router or switch.

SECTION 3 – Installation; Typical Configuration

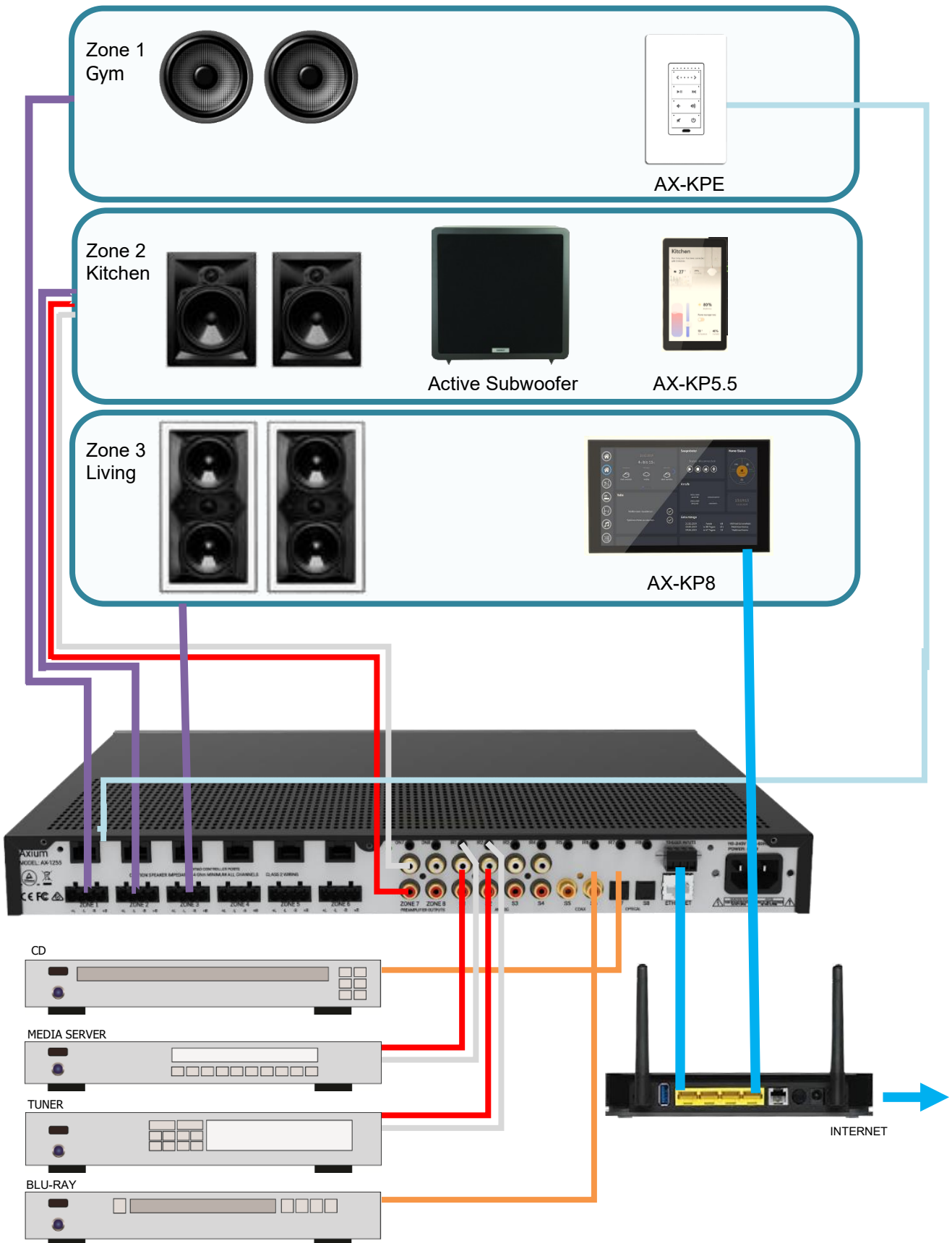

SECTION 3 - Typical System Configuration

FIG 1 depicts a typical configuration where the AX-1255 amplifier is providing audio into six of the possible eight listening zones. Only three of the Zones are depicted.

Each zone consists of a room with a pair of speakers and a suitable controller.

Each zone may be listening to any of the connected sources: Blu-ray, Tuner, Media server, CD changer etc.

Controllers

Each zone has a specific control requirement. Choose controllers that best suit the application.

- Zone 1 – The Gym: Keypad via controller port
- Zone 2 – The Kitchen: Keypad via Wifi
- Zone 3 – The Living: Tablet via Ethernet

The Axiom Keypad's may be plugged into any of the 6 Controller ports.

Source control IR emitters are plugged into the IR Ports. There are 8 IR ports: IR1 - IR8.

IR 1 – IR8 route source specific IR signals from connected controllers.

When controlling the AX-1255 using a mobile device, the AX-1255 must be connected to a WIFI enabled Ethernet router and the Web Tablet browser must be loaded with the Axiom APP available from the appropriate store. Without the ability to load an app the amplifiers web page can be loaded via a browser on the mobile Device.

The AX-1255 can store and regenerate source equipment IR commands, and be directed to output the IR commands to a specific IR output port as required. This advanced feature is programmed using the Axiom Design Portal program (ADP)

Speakers

Speakers in each zone are connected to the amplifier by "Home Run" speaker cables.

Source Equipment

The AX-1255 amplifier has eight audio inputs for connecting to source equipment. These input channels feature Analog L+R, Coax Digital and Optical Digital inputs. Digital Inputs are PCM only

A zone may select from any of the connected sources.

Someone in the Lounge may be listening to the Tuner while another in the Study may be listening to music from the media server.

All eight zones may select the same source.

Preamplifier Zone Outputs

The preamplifier output zones are completely independent of the Digital Amplifier Zones. These can optionally be used for locations where a high or lower power amplifier / speaker would be required.

A preamplifier Zone may be Zone linked to one of the Digital amplifier zones and provide line level outputs to a subwoofer. This is what is shown in the Study, where the preamplifier zone 7 provides the active subwoofers line level. In this case Zone 7 must be Zone Linked to Zone 2 and Zone linking options for Link Volume and Link Standby have been selected. The zone 7 EQ must have a low pass filter frequency selected.

SECTION 3 - Controller Wiring

- **ETHERNET:** 100BaseT.
Connect to a network router or switch.
- **CONTROLLER PORT:**
Conveys +12VDC, IR and Data between the AX-1255 and Axiom keypad controllers or Infrared, connected using CAT5 cables.
A low current 12v zone amp on os provided per zone.
The Port may be setup to be Zone assigned i.e. a Controller connected to Port 1 controls only Zone 1 etc.
- **AMPON 7 - 8**
Amp ON is +12VDC 100mA trigger output.
- **PRESETS:**
IN1 and IN2 Inputs are active high by default.
A Push to Make switch is used to trigger the Preset.
However, this can be swapped in the settings to allow active low, where in this case a Push to Break switch is used to trigger the Preset.

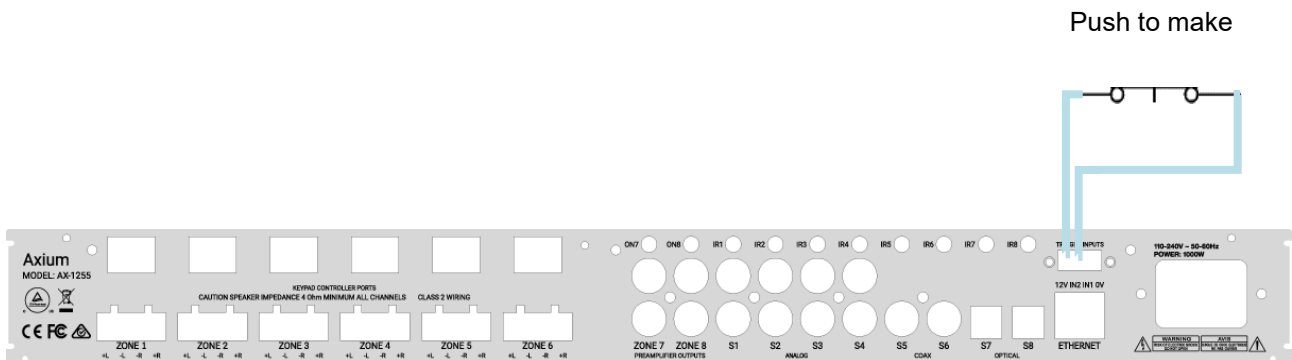

SECTION 4 - Menu Navigation: User

Front Panel User Interface:

The AX-1255 amplifier has a 2.4" Touch Panel LCD colour display which is used for control and accessing status of all amplifier functions.

After 2 minutes of inactivity the LCD dims to 50% brightness, after a further 15 minutes it dims OFF.

A Touch on the screen will restore the LCD to full brightness, enabling touch control.

Home Page

The home page provides access to the Amplifier zones: Zone1 - Zone 8. Selecting a Zone opens its control page. The Blue indicators in the buttons provide zone standby status.

The first six zones are the amplifier outputs, the last two zones are the preamplifier outputs.



Zone Control Page

At the top of the control page the Zone name is displayed.

The 'Zones' button is the Home Page return.

The Control page provides status & control for the selected Zones:

- Standby
- Volume Slider
- Volume Up / Down with Digit readout
- Source Selects S1 – S4
- Mute

The selected source has an illuminated blue indicator.

The Volume slider changes colour as the volume increases, i.e. Green –Yellow – Red.

Selecting the 'More' button will button will cycle through any other available sources. If the internal AMM is installed then "Media 1" - "Media 4", "Media 5" - "Media 8" and then through any manually or automatically configured distributed sources.



SECTION 4 - Menu Navigation: User

More Functions Page

When the “More” button is pressed and held for >1second a More functions Page opens.

There are four Zone specific functions that when selected navigate to setup pages:

- EQ
- Levels
- Zones
- Delay

There is also a System function which is not zone specific. The System page is covered later. Note System functions may be accessed via any of the Zones ‘More functions’ pages.

The Back arrow button returns to the Zone Control Page.



EQ Setup Page

The EQ setup page provides status & control for the selected Zones:

- Bass \pm 12dB using Slider or Up/Down button
- Treble \pm 12dB using slider or Up/Down Button
- Loudness Control – toggle.

The Back arrow button returns to the More Functions Page.

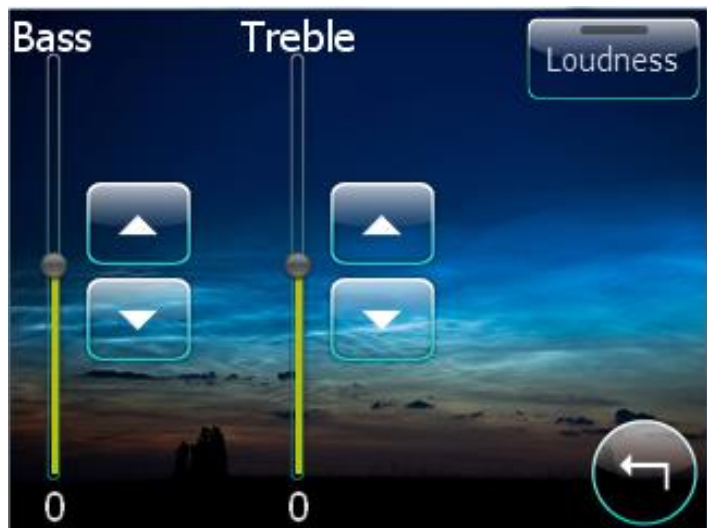

The Preamp zones have an additional ‘Low pass filter’ button on the EQ setup page. When selected a ‘Low Pass Filter’ page opens.

There are four low pass filter options:

- 80Hz
- 120Hz
- 180Hz
- 240Hz.

Select the setting most appropriate for the connected Sub woofer.

When a low pass filter is selected the Tone and loudness controls are defeated.

The Back arrow button returns to the More Functions Page.



SECTION 4 - Menu Navigation: User

Levels Setup Page

The Levels setup page provides status & control for the selected zones:

- Maximum Volume Limiting – can be reduced over the range from 100 to the minimum of 2 using the slider or Up/Down buttons.
- Gain – can be adjusted $\pm 12\text{dB}$ in 2dB steps using the slider or Up/Down buttons
- Mono – if selected will combine Left and Right signals.

The 'More' button navigates to a further Levels setup page

The Back arrow button returns to the More Functions Page.

The Levels setup page 2 provides status & control for the selected zones:

- Balance - $\pm 20\text{dB}$ of adjustment in 2 dB steps can be made using the slider or Left/Right buttons.
- Power On Volume – Volume level can be adjusted over the full Volume range using the Slider or Up/Down buttons. The function is enabled when the 'Enable' button is selected.

The Back arrow button returns to the Levels Setup Page.

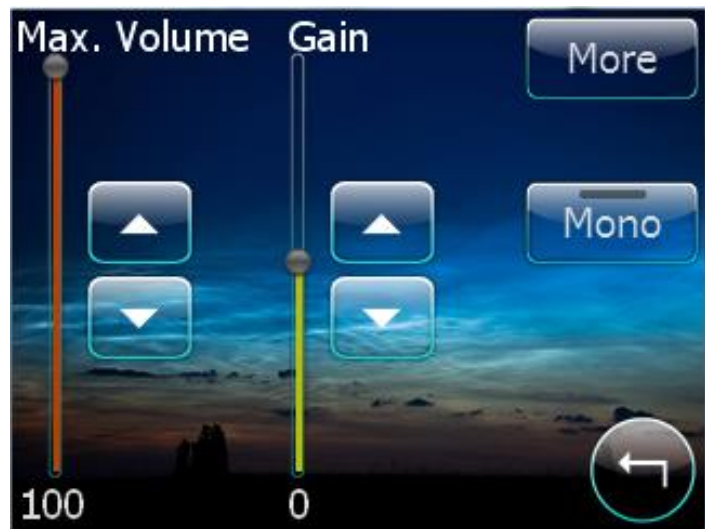

Delay Setup Page

The Delay setup page provides a single slider and Up/Down control for adjusting the Zones Audio Delay time. It may be adjusted over the range from 0 – 600ms in 5ms steps

The S1 – S8 buttons may be selected to be included or de-selected to be excluded from the delay group.

SECTION 4 - Menu Navigation: User

Zones Setup Page

Zones setup page provides the means to set the Zone coding.

There are also Buttons for Zone Linking setup and Zone Name editing.

To change the Zone allocation simply make the adjustment using the Up/Down button.

The Back arrow button returns to the More Functions Page.

To Name the Zone select 'Edit'
The Zone Name Page opens:

To setup the Zone Linking select the 'Zone Linking' button:



Zone Name Page

Use the keypad to enter the Name text,
The limit is 15 regular ASCII characters.

Once entered, select the back arrow to return to the Zones Setup Page.



Zone Linking Page

The zone may be linked with any other zone or zones. Make the selection by scrolling through the zone list and choosing OK.

The Type of Zone Linking:
Link Volume or Link Standby may be selected.
When Link volume is selected the linked zone(s) will track the source and volume settings.
When Link Standby is selected the Linked Zone(s) will behave as if they are the same zone.
Once entered, select the back arrow to return to the Zones Setup Page.



SECTION 4 - Menu Navigation: System

System Page

The System settings page opens when the System button is selected in any of the 'More function pages' for longer than 5 seconds. The System settings are Zone independent functions. The page displays the internal amplifier heatsink temperature.

Select the Close button to return to the Zone Page.

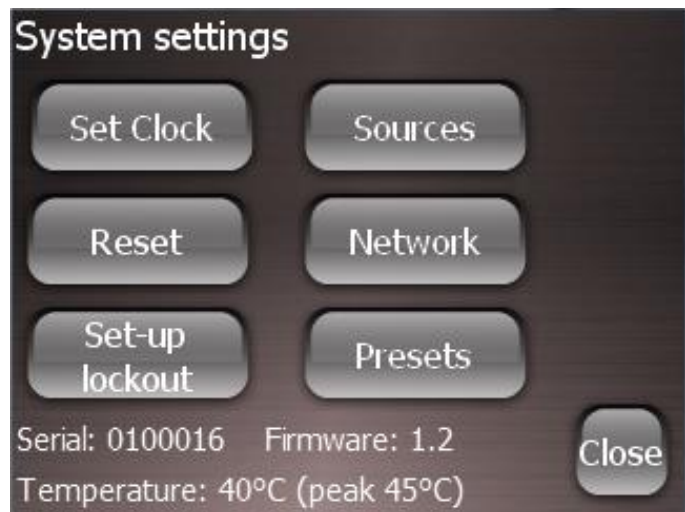

Set Clock Page

The clocks time and time zone are automatically synchronised when connected to the internet or to a PC using the USB connection. However the clock settings and how the clock is displayed may be adjusted.

Select the Back arrow to return to the System settings Page.



Restore Defaults Page

To fully restore the AX-1255 to factory defaults, select 'Restore Defaults' then select 'Yes', or to return to previous menu select 'No'. Factory defaults resets the zone allocations back to 1 - 8 Clears all settings like Zone and Source Names, Presets, Zone linking, gain adjustments, Maximum volume limits, Bass, Treble and Loudness etc.

Alternatively to reboot the system select the 'System Reboot' button, then select 'Yes', or to return to previous menu select 'No'.

Select the Back arrow to return to the System settings Page.



SECTION 4 - Menu Navigation: System

Setup lockout Page

You may lock the user out from making critical installation setting changes by enabling the Setup lockout. Once set the user cannot access the System Settings menus. Select 'Yes' to enable this option, or 'No' to return to the previous menu.

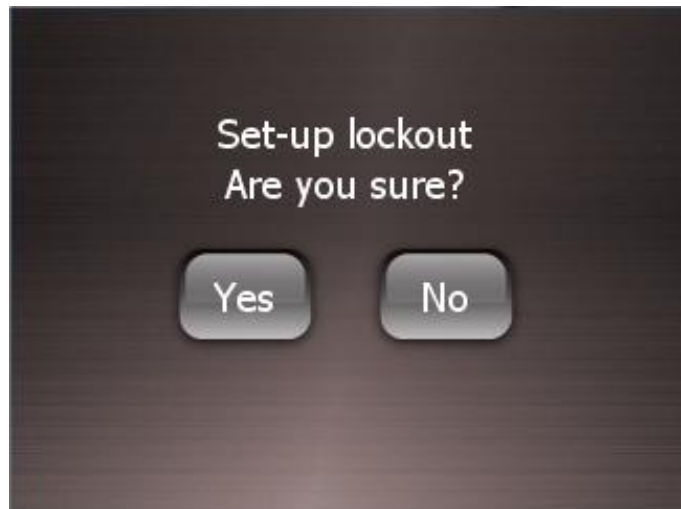

Sources settings Page

Select the Source to be adjusted
From S1 – S8.

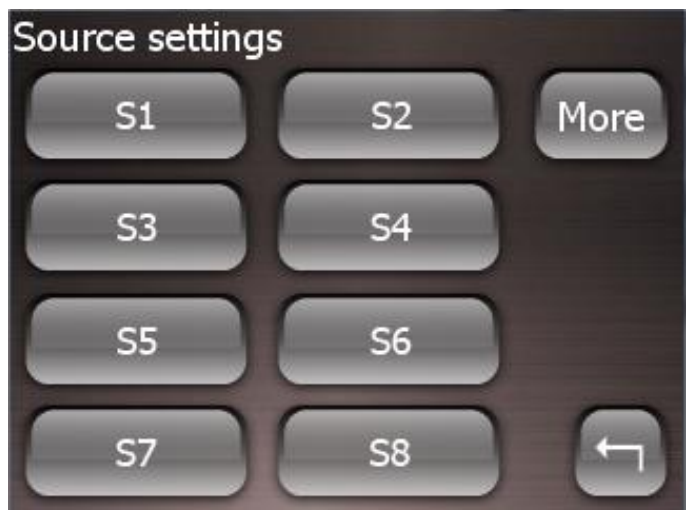

A Source may be named, by using the phone Keypad.
Input gain can be adjusted using the Gain slider or Up / Down buttons.
Gain is used to match the input levels of sources. Some Analog sources have large variation in output levels. The 0dB default setting is suitable for connection to high output devices like DVD players, while the standard level (1Vrms) is achieved by setting the gain to +6dB.
Select the Back arrow to return to the System settings Page



SECTION 4 - Menu Navigation: System

Network settings Page

Network setting always defaults to DHCP. The connected Ethernet router's allocated IP address can be viewed. If for some reason a Static IP is required the selection can be made, and settings adjusted using the back and forward arrow and plus minus keys.

Select the Back arrow to return to the System settings Page.

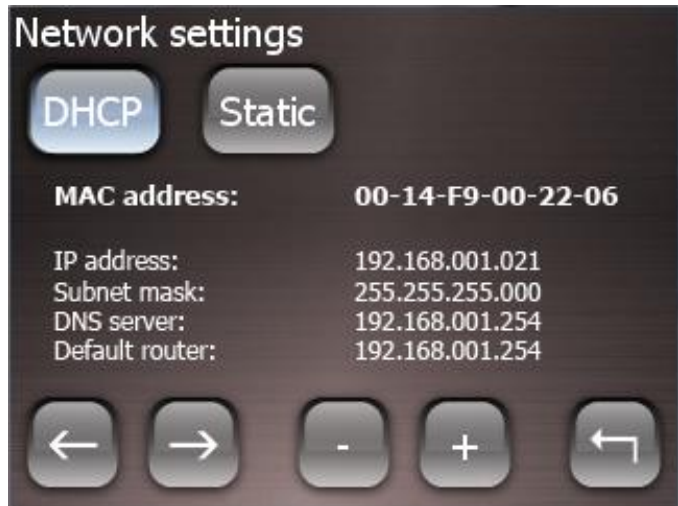

SECTION 5 - Web Application: Monitor and Control

The Axiom AX-1255 amplifier has a Web application which may be used for, control, monitoring and configuration of amplifier functions.

In a Browser enter either the connected amplifiers default NetBIOS name or the IP address which is assigned by the connected Router. i.e. <http://AX1255-00016> or <http://192.168.100.24>

Zone Control Page

This page provides access to the Amplifier Zones.

The first Zone defaults to the name Location 1, all other zones if unnamed are listed as Zone 2, Zone 3 etc.

Selecting a Zone opens the individual Zone control page.

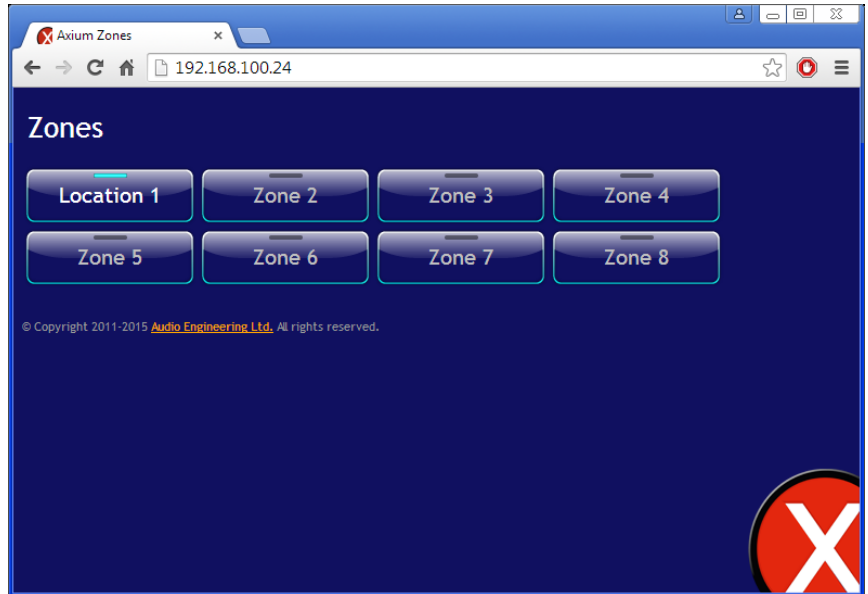

Zone Control Page

When selecting a Zone, a status & control page appears providing.

- Standby
- Mute
- Volume: Slider or Up/Down button with readout.
- Source Selection: Media Selection and any Conditional sources
- If Media1 is the selected Source; then Media Navigation and Player functions are displayed.

A blue button indicates selection or Power ON status.

Because of Web browser limitations, Slider setting changes are made using a positional touch on the slider

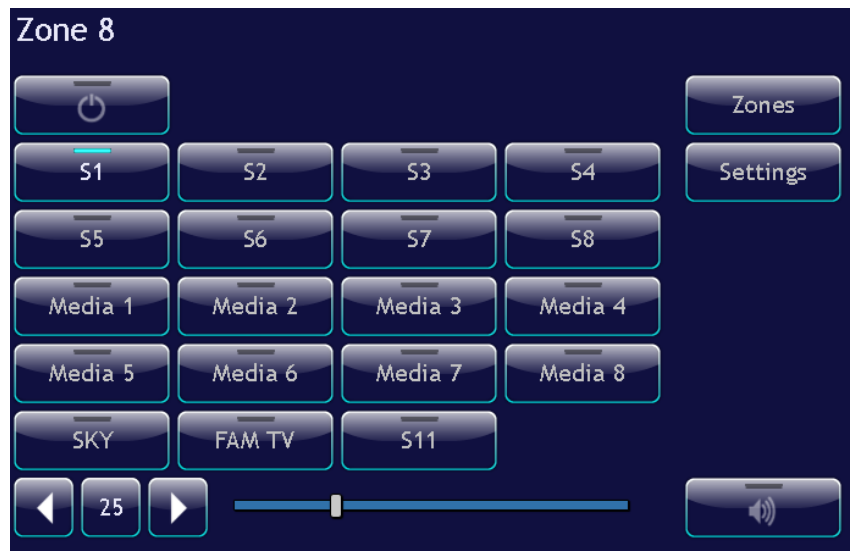

The 'Zones' button is the Home Page return back to the "home" page of listed zones. The 'Settings' button opens the Settings page.

SECTION 5 - Web Application: Monitor and Control

Zone Settings Page

The Zone Settings Page provides status & control of:

- Bass control
- Treble control
- Loudness
- Mono
- Balance: Slider or Left/Right button
- Gain: Slider or Up/Down button
- Maximum Volume Limit:
- Power On Volume:
- Delays for each Source: S1 – S8:

The EQ button opens a 7 band Parametric equalisation page detailed on the next page.

A “Low-pass” filter button is provided which applies a Subwoofer optimised low pass filter for the zone. This is designed for use when a Subwoofer is used in the zone. This filters functions can be optimised in the EQ page.

The Loudness button activates the Axiom OBC “Optimised Bass Control” function where a volume dependent bass boost is applied to the zone.

A low frequency bass boost is applied to the zone at low volume to compensate for a persons ears natural reduction in sensitivity to bass at low volume. This feature improves the bass response of small speakers at low volume significantly improving overall listening enjoyment.

The boost effect reduces as volume increases preserving the full zone’s headroom and to not overload smaller speakers like a tone control where the boost level is applied over the full volume rang.

The Back arrow button returns to the Zone Control Page.

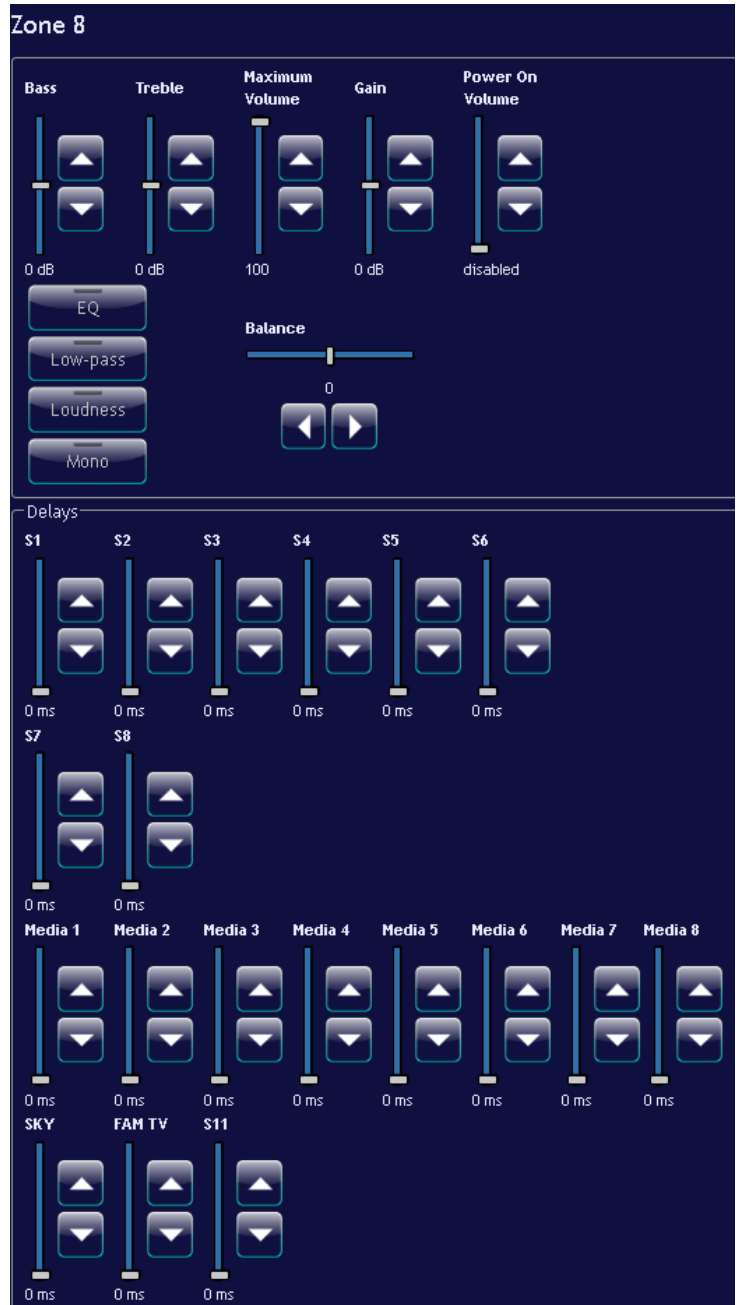

SECTION 5 - Web Application: Monitor and Control

EQ Configuration Page

The EQ settings page provides the ability to adjust 7 individual frequencies, bandwidth and gain settings to customise a zones frequency response to suit particular needs, ie Subwoofer crossover parameters, or compensation for a particular speaker or environmental effect.

The Close arrow button returns to the Zone Control Page.

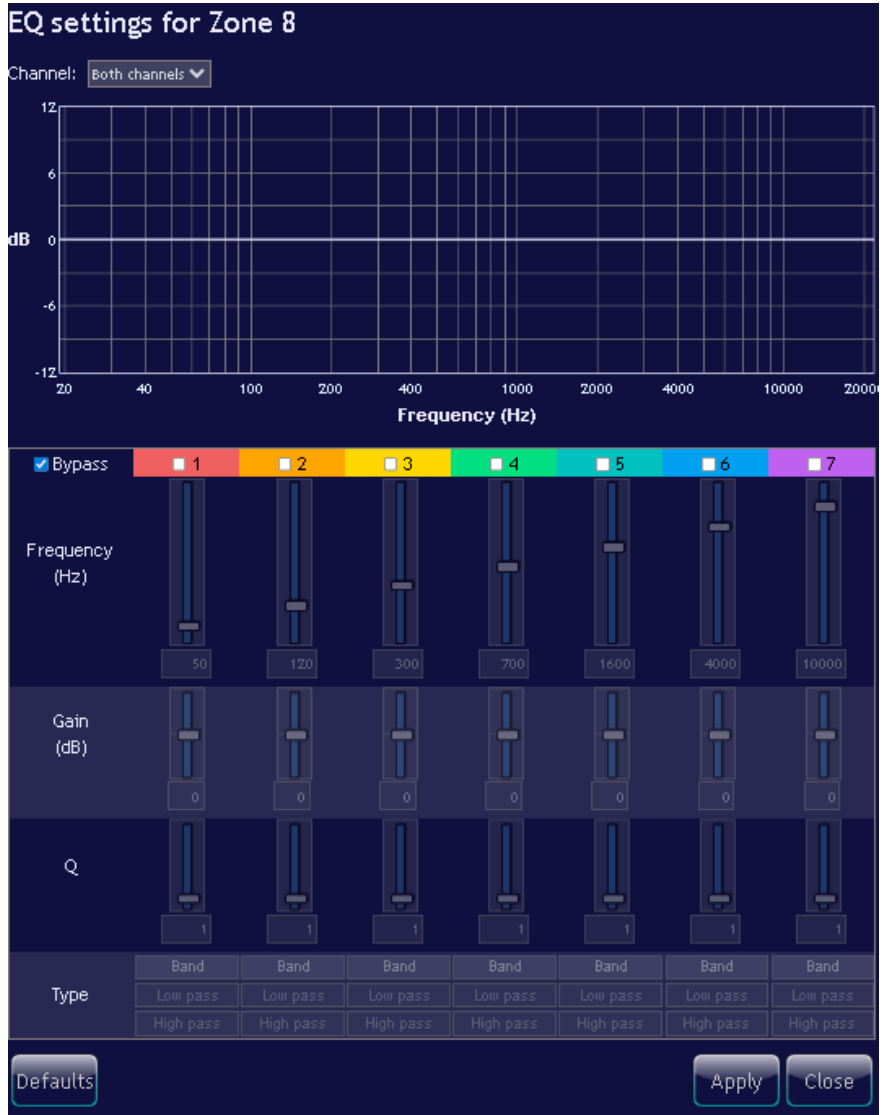

SECTION 5 - Web Application: Configuration

To access configuration pages, in the browser enter either the NetBIOS name or IP address with a `/config` extension. i.e. <http://192.168.100.24/config>

Device Configuration Page

Device information:

- Model
- Unit ID
- Manufacture Date
- Installed Firmware Version
- Temperature of amplifier heatsink
- IP address
- MAC address.
- Amplifiers assigned Network name

Wired Ethernet:

The Network configuration is DHCP by default. A Static IP address may be selected; IP settings will appear in a drop-down and include IPV6.

Date & Time:

Configure the NTP server and if/when Daylight Saving time is observed.

Third Party Support:

2 way driver support for . KNX, HDA MHub, Vantage integration with more to come.

Volume Ramp Speed Limit:

Slows volume control ramp speed.

Auto Power On / Standby:

Zones are optionally turned on and off depending on whether audio is present on the selected source.

Important Note this setting can cause what appears to be random zone on and off functions in particular if usage changes in the future so please use with consideration to usage both at setup and in the future.

More Devices:

The More Devices Section shows a list of other Axium devices that are on the network, if any, and provides access to their web interfaces when clicking the “Configure” button next to their name.

SECTION 5 - Web Application: Configuration

Zones Configuration Page

All Axium amplifiers on the network are listed.

Zone Settings:

The Zone Name may be changed – click on the name to edit.

These names will appear on connected Keypads and Tablets running the Axium App.

The Devices physical Zones 1- 8 may be configured with a different logical zone or system zones: ranging from 1 – 96.

Each Keypad port can have a zone assigned. This enables source specific IR routing and for keypads that support this feature. The Axium KPE keypad's zone will be automatically assigned depending on its keypad port connection.

Amp Zone	System Zone	Zone Name <small>(click name to edit)</small>
Zone 1	3	KITCHEN
Zone 2	10	MBED BATH
Zone 3	4	MASTER BED
Zone 4	Disabled	
Zone 5	5	OFFICE
Zone 6	6	MASTER BED
Zone 7	1	FAMILY
Zone 8	2	FAMILY

Keypad Port	System Zone
Port 1	3
Port 2	10
Port 3	4
Port 4	8
Port 5	5
Port 6	6
Port 7	1
Port 8	2

Unused zones can be disabled by setting their system zone number to "Disabled" so they don't clutter user interfaces. in particular.

Zone Linking:

Zones can be linked together with any combination of source selection, power and volume. These settings apply to all zones in the linked group.

There is no limit to the number of zones in a group, but a zone may only be a member of a single group.

If multiple zones are combined 1 Zone using the Merge function, only 1 zone will appear in the Axium connected Keypads and Tablets running the Axium App.

ID	Linked System Zones	Options
1	1,2	[Power] [Volume] [Source] [X]
2	4,6	[Power] [Volume] [Source] [X]
3	11,12	[Power] [Volume] [Source] [X]

Add Group

SECTION 5 - Web Application: Configuration

Source Configuration Page – Source Settings

This page allows Source renaming by clicking on the Name and changing it..

Sources are shown against colour coded backgrounds to show what type of source type/connection is used.

The ticked **Enabled** sources will appear in connected keypads and Mobiles running the Axiom Application.

Unticked sources do not appear in the Axiom App or Keypad to reduce the number of sources visible.

The **Gain** of each source can be adjusted to match other source inputs, keeping volume consistent when switching between sources.

Physical Source	Name	Enabled	Independent	Audio synchronisation	Gain
Source 1	S1	<input checked="" type="checkbox"/>	<input checked="" type="checkbox"/>	real-time	0dB
Source 2	S2	<input checked="" type="checkbox"/>	<input checked="" type="checkbox"/>	real-time	0dB
Source 3	S3	<input checked="" type="checkbox"/>	<input checked="" type="checkbox"/>	real-time	0dB
Source 4	S4	<input checked="" type="checkbox"/>	<input checked="" type="checkbox"/>	real-time	0dB
Source 5	S5	<input checked="" type="checkbox"/>	<input checked="" type="checkbox"/>	real-time	0dB
Source 6	S6	<input checked="" type="checkbox"/>	<input checked="" type="checkbox"/>	real-time	0dB
Source 7	S7	<input checked="" type="checkbox"/>	<input checked="" type="checkbox"/>	real-time	0dB
Source 8	S8	<input checked="" type="checkbox"/>	<input checked="" type="checkbox"/>	real-time	0dB

Legend: ■ -analogue ■ -coax ■ -optical

The Unticked **Independent** configuration is used when a source is physically connected to the same source input on all amplifiers in a stack/system.

This is used when Amplifiers do not have the Axiom Distributed Source System enabled and a source has to be physically connected to all amplifiers in a system for them to be able to play the source.

When the **Independent** checkbox is ticked (the default setting), each input is unique and thus independent from any other source in the system, therefore amplifiers do not have to be positioned in the same physical location in a system, they just need to be on the same network. A system containing 2 or more amplifiers can have different devices connected to either amplifier and seamlessly play music from any device.

Source inputs expand with additional amplifiers. A source only needs to be connected to one Axiom amplifier in a system. The Axiom Distributed Source System enables any source to stream to any other amplifier/s in the system over the local network. Operation of this system is totally transparent to a user, who sees all sources available in the system no matter what amplifier the source is connected to. The system also allows seamless whole house audio playback of time synced playback of the same audio content in every zone, time to party.

Source content is streamed between amplifiers unmodified from the original format and is not compressed.

The AX-1255's analogue sources are sampled at 96 kHz 24 bit and so they will be streamed at 96 kHz. The digital sources are streamed at the original sample rate, for example audio coming from a CD will be streamed at 44.1 kHz

A maximum of 32 concurrent sources (network dependent) can be streamed at any time.

Audio Synchronisation is used when streaming the source as a "distributed source" to another amplifier over the local ethernet.

"Real-time" prioritises low latency and is used when the audio needs to be synchronised with a TV panel (lip sync) or other real-world references.

"System-wide" makes synchronisation between all zones the priority and latency is added for buffering against drop-outs on WiFi connected amplifiers (which, for example, can also include an AX1255s via a WiFi link).

SECTION 5 - Web Application: Configuration

Source Configuration Page – Distributed Sources

Axiom has developed a very high quality, reliable system of sharing source content between Axiom amplifiers across a local network.. The system allows the user to seamlessly select and listen to any enabled source on any amplifier no matter where the source is located in the system. The system also allows seamless whole house audio playback of time synced playback of the same audio content in every zone, time to party.

By default the “Allow Automatic Assignments” setting is enabled to provide plug and play functionality of the system. In this mode, any enabled source on any amplifier is included in the Distributed Sources System, Axiom Apps and Keypads display all the active sources, any source can be selected and played in any zone, Note: When the Automatic Assignments is activated, the table is not populated.

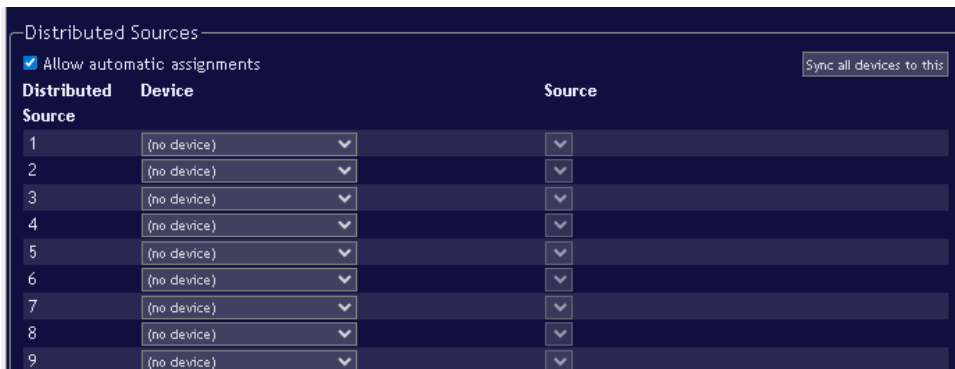

If the user does not want a source distributed, that is, available in all zones then, the source can be disabled (untick the enabled box for the source) or the distributed source table can be setup manually with just the sources wanted to be available in other zones. (As soon as there is a manual assignment for an amplifier then the amplifier is excluded from automatic assignments.) It is NOT recommended to have a mix of automatic and manual assignments on different amplifiers, if you make a manual assignment then turn off the automatic assignments on all amplifiers and setup the sources on each amplifier manually.

If there is a difference in the distributed source table when an amplifier has had manual adjustments, a warning of a conflict will appear in the sources tab. Clicking on the yellow warning indicator will highlight the conflict that needs resolving.

Common sources of conflict can occur if some amplifiers have the " Automatic Assignments" on and others have it off, In this mode making changes will cause different distributed source table settings and system conflicts. Be careful to update all amplifiers when making manual assignments. It is also imperative that all amplifiers are online, otherwise the manual assignments will not be made on any amplifiers being added later, causing a conflict.

When making changes or in order to resolve table conflicts there is the ability to either apply settings from another device or to make changes to one amplifier and Sync these settings to all other amplifiers.

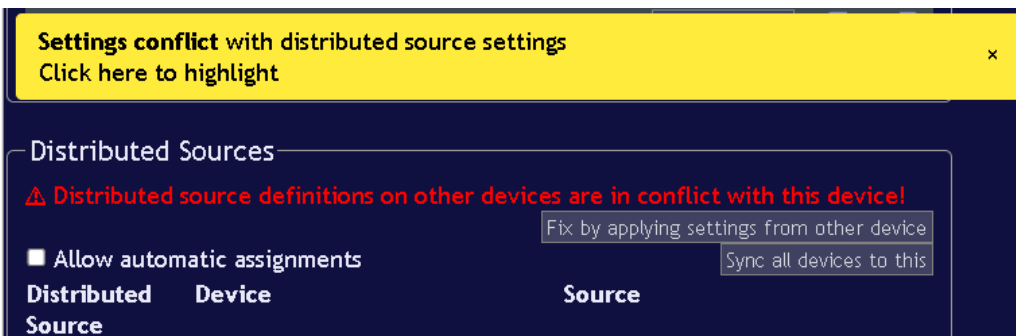

SECTION 5 - Web Application: Configuration

Preset Configuration Page

A sophisticated Preset configuration page is provided. These are a set of predefined settings that can be activated manually, by a timer (alarm) or by a trigger. They are generally used for quickly configuring zones for a particular scenario such as initiating a user's preferred music and settings, applying settings for a party, as an alarm clock, for temporary interruptions for a doorbell or paging, etc. When activated, they can initiate playback from media favourites, such as radio stations, and can play short user defined sounds.

There are 15 system-wide presets.

Preset properties:

- Name - presets can be given a user friendly name to indicate their purpose.
- Trigger activation settings - presets can be activated using external signals or when audio is detected on a source input.
- Sound playback settings - presets can optionally play short sounds once or repeatedly.
- Media favourite - presets can optionally initiate playback of media favourites.
- Zones - presets can affect any combination of the 96 zones available on an Axium system.
- Alarm - time and weekdays when a preset can be automatically activated.

Presets are configured firstly by setting the appropriate properties and then using the "Preset to set up" selection which puts the system in a special preset set up mode. While the preset set up mode is active, the user can set the desired sources, volume and power/standby settings in the zones that are included in the preset properties. Once the settings have been made, the system must be returned to normal operating mode by reselecting "(none)" in the "Preset to set up" selection.

Presets

Presets are configured in a grid of 15 buttons:

Preset A settings	Preset B settings	Preset C settings
Preset D settings	Preset E settings	Preset F settings
Preset G settings	Preset H settings	Preset I settings
Preset J settings	Preset K settings	Preset L settings
Preset M settings	Preset N settings	Preset O settings

Preset set up

Preset to set up: (none) ▼

Triggers

Trigger inputs active on:

- Contact open (normally closed)
- Contact close (normally open)

Trigger Input 1

Action: Preset ▼

Preset: Preset A ▼

- Play preset sound on activation
- Restore settings after trigger
- Activate when audio detected on source S1 ▼

Do not disturb

Time: 00 : 00 - 00 : 00

Substitute preset: (none) ▼

Trigger Input 2

Action: Preset ▼

Preset: Preset B ▼

- Play preset sound on activation
- Restore settings after trigger
- Activate when audio detected on source S1 ▼

Do not disturb

Time: 00 : 00 - 00 : 00

Substitute preset: (none) ▼

SECTION 5 - Web Application: Configuration

Preset Configuration Page

Trigger Inputs

The AX-1255 has 2 trigger inputs which can be used for activating presets or for powering on and off all or specific zones (amp-on trigger). There is a general selection that selects if the triggers are activated by contact open or contact closure. Depending on the type of doorbell used, a doorbell contact might be open or closed when it is activated. Contact close (normally open) is the usual setting for most push-buttons.

When used for preset activation, each trigger has the following properties:

- Preset - the preset that is activated by the trigger.
- Play sound on activation - selects if the preset's sound is played when the preset is activate by the trigger. This is useful for doorbells or paging.
- Restore settings after trigger - this is selected if the preset activation is only a temporary interruption and the original settings are restored after the trigger is released and any optional sound has finished playing (doorbell/paging). If not selected then the preset settings are applied when the trigger activates without restoring the original settings when the trigger is released.
- Activate when audio detected on source - The triggers can also optionally activate if audio is detected on a particular source input.
- Do not disturb - Between certain times, an alternative preset can be activated that can apply to a different selection of zones and use different settings. For example at night it might be desirable to have a doorbell play in fewer zones and with reduced volume than during the day.

Sounds

The AX-1255 can store up to four sounds that can be played on the zones hosted by the AX-1255 when presets are activated. A predefined selection of doorbell sounds are provided but the user is free to use any sound provided it fits within the available memory. Several settings are provided that reduce the size and quality of the sound file. A "Listen" button plays the sound via the web browser (on the device displaying the web interface) and is provided for evaluating the sound and its quality. Once the sound and its settings have been selected, the "Upload" button is used to store the sound on the AX-1255. It is not recommended to use up all of the available memory with sounds.

SECTION 5 - Web Application: Configuration

IR Routing Configuration Page

IR signals received on any one of the IR inputs do not need to be transmitted on every IR output.

Use of the IR Routing feature enables control over which IR outputs transmit an IR signal depending on its origin and optionally the currently selected source.

Source specific IR routing is useful for controlling source equipment and is available for all keypad ports that have a zone selection on the zones page.

IR input: selects the keypad port to setup IR routing.

Selected IR outputs: Is a table of check boxes that when checked transmits Amplifier source related IR to specific IR outputs.

Control Device Zones Sources Presets **IR Routing** Management

IR Routing

IR input: Keypad port 1

Selected IR Outputs

	S1	S2	S3	S4	S5	S6	S7	S8	
Output 1	<input checked="" type="checkbox"/>	<input checked="" type="checkbox"/>	<input checked="" type="checkbox"/>	<input checked="" type="checkbox"/>	<input checked="" type="checkbox"/>	<input checked="" type="checkbox"/>	<input checked="" type="checkbox"/>	<input checked="" type="checkbox"/>	None
Output 2	<input checked="" type="checkbox"/>	<input checked="" type="checkbox"/>	<input checked="" type="checkbox"/>	<input checked="" type="checkbox"/>	<input checked="" type="checkbox"/>	<input checked="" type="checkbox"/>	<input checked="" type="checkbox"/>	<input checked="" type="checkbox"/>	None
Output 3	<input checked="" type="checkbox"/>	<input checked="" type="checkbox"/>	<input checked="" type="checkbox"/>	<input checked="" type="checkbox"/>	<input checked="" type="checkbox"/>	<input checked="" type="checkbox"/>	<input checked="" type="checkbox"/>	<input checked="" type="checkbox"/>	None
Output 4	<input checked="" type="checkbox"/>	<input checked="" type="checkbox"/>	<input checked="" type="checkbox"/>	<input checked="" type="checkbox"/>	<input checked="" type="checkbox"/>	<input checked="" type="checkbox"/>	<input checked="" type="checkbox"/>	<input checked="" type="checkbox"/>	None
Output 5	<input checked="" type="checkbox"/>	<input checked="" type="checkbox"/>	<input checked="" type="checkbox"/>	<input checked="" type="checkbox"/>	<input checked="" type="checkbox"/>	<input checked="" type="checkbox"/>	<input checked="" type="checkbox"/>	<input checked="" type="checkbox"/>	None
Output 6	<input checked="" type="checkbox"/>	<input checked="" type="checkbox"/>	<input checked="" type="checkbox"/>	<input checked="" type="checkbox"/>	<input checked="" type="checkbox"/>	<input checked="" type="checkbox"/>	<input checked="" type="checkbox"/>	<input checked="" type="checkbox"/>	None
Output 7	<input checked="" type="checkbox"/>	<input checked="" type="checkbox"/>	<input checked="" type="checkbox"/>	<input checked="" type="checkbox"/>	<input checked="" type="checkbox"/>	<input checked="" type="checkbox"/>	<input checked="" type="checkbox"/>	<input checked="" type="checkbox"/>	None
Output 8	<input checked="" type="checkbox"/>	<input checked="" type="checkbox"/>	<input checked="" type="checkbox"/>	<input checked="" type="checkbox"/>	<input checked="" type="checkbox"/>	<input checked="" type="checkbox"/>	<input checked="" type="checkbox"/>	<input checked="" type="checkbox"/>	None

© Copyright 2011-2026 Audio Engineering Ltd. All rights reserved.

SECTION 5 - Web Application: Configuration

Media Configuration Page

By installing a AMM media manager PCB via the window provided under the amplifier, a “Media” tab will appear in the web amplifier configuration page, 8 independent streaming sources will be enabled in the sources and distributed sources table.

Additional media services can be selected and activated from this page. Depending on the media source additional username and passwords may be required, or additional functionality provided by the media streaming company

Audio streaming partners and voice service providers will be updated via FW.

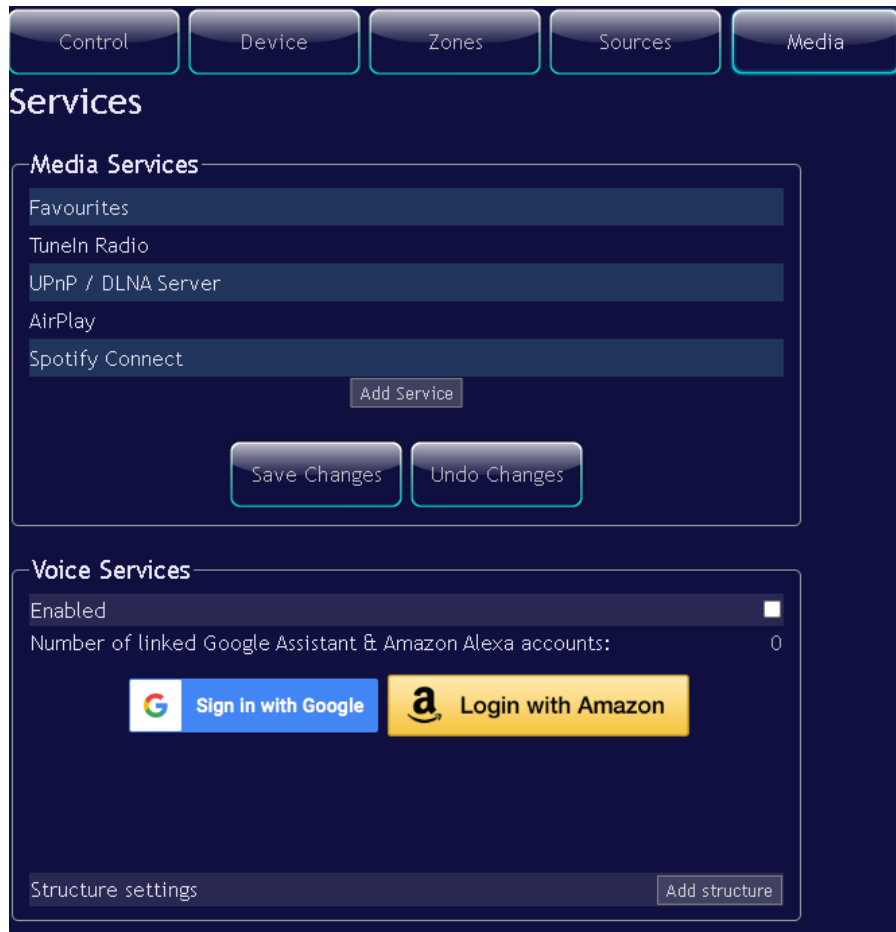

SECTION 5 - Web Application: Configuration

AMM Media Manager PCB installation instructions

The Media Manager is a Small PCB that can be installed in the amplifier via a small Access Panel located in the base. The pin configuration allows installation in only one direction. The AMM will be pre-programmed and tested before installation.

Image of the PCB.

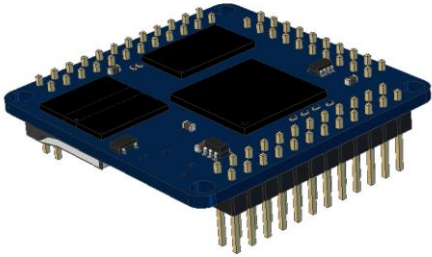

The Procedure to install the AMM PCB

- Remove AC power cable from AX-1255 for at least 1 minute (60 seconds) before proceeding.
- Turn AX-1255 over to identify the access panel in the base.
- Remove the Access Panel M3 fixing screw then the Access Panel. Keep the access panel and screw for reuse.
- Insert the AMM fully by carefully aligning and inserting the AMM pins into the headers in the PCB via the hole in the base.
- Re-insert the Access Panel back into position, and refix with the M3 screw.
- Turn the amplifier over onto its feet and reapply the Power lead.

Do not remove the Thermal PAD (25mm x 25mm x 2mm) that is adhered to the top of the AMM board. The PAD helps remove heat from AMM's IC's to the Metal Access Panel and ensures the AMM NEO remains firmly located in position.

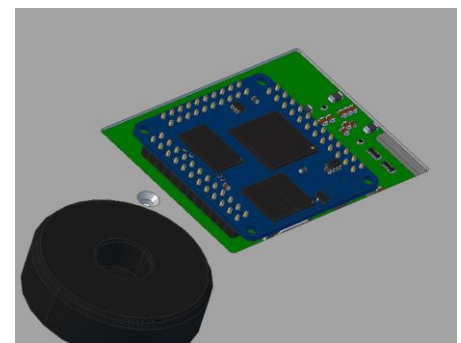
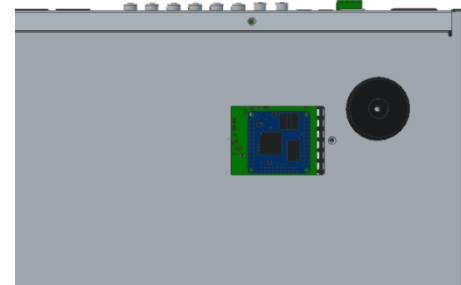
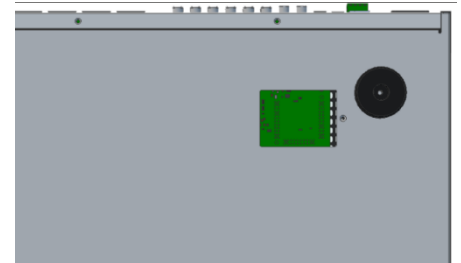
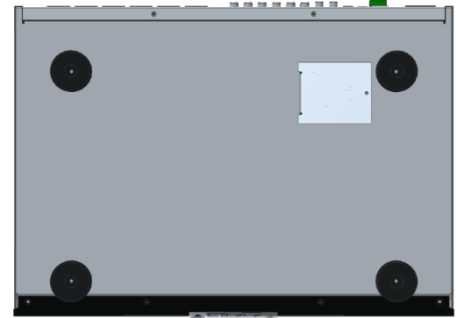

SECTION 5 - Web Application: Configuration

Management Page

Diagnostic Log: Is a useful tool for diagnosing connection issues and possible faults.

This log is not stored in memory – so information is only collected from the current active power cycle.

Events: Non-volatile log of certain parameters like power interruptions, high temperature events, etc

Device Maintenance

Backup of the current device configuration can be saved and used to restore or copy functionality.

Reset

Restore Defaults resets the amplifier back to factory defaults, clearing all the configuration settings. A one button Amplifier Reboot is provided.



SECTION 6 - Specifications

Amplifier Section

Rated Output Power:

8 Ω Loads 1% THD:	55 Watts / channel
4 Ω Loads 1% THD:	98 Watts / Channel
All Channels Driven 4 & 8 Ω loads 1% THD	52.5 Watts / channel
Damping Factor (8 Ω Load)	45
Speaker Impedance (Z1 – Z6 L/R)	4 Ω - 8 Ω
Volume control range	100 dB in 1dB steps with speed adjustment

THD (Total Harmonic Distortion)

Signal to Noise

Channel Separation

<0.1% (50 Watt, 8 Ω load)
105dB (IHF-A)
>83dB

Analog S1 – S4 Inputs

Sensitivity (S1 – S4)	0.75V _{RMS} (Vol 100, Gain 0dB, 55W Output)
Input Impedance (S1 – S4)	22K Ω

Digital Coax S5 – S6 & Optical S7 – S8

Input Sensitivity	0dBfs
Sample Rate	44.1KHz – 192KHz

Preamplifier Zone 7 & Zone 8

Preamplifier Output Level	+6dB
Frequency Response: Analog inputs	10Hz – 22KHz

Tone Control

\pm 12dB, 100Hz (Bass)
\pm 12dB, 10KHz (Treble)

Frequency Response

Digital 44.1 - 192kHz sample rate	10 Hz – 44 kHz
Analogue	10 Hz – 22 KHz

Interface

IR Output	Eight 3.5mm Jack: IR1 – IR8 current limited to 25mA.
Ethernet	100Base T
Preamp ON	Two 3.5mm Jack: ON7 and ON8 current limited to 25mA.
Controller	Six RJ45 Socket
Trigger Inputs	One 4way terminal plug with 0V, IN1, IN2, 12V

General

Power Supply	110 - 240VAC 50/60 HZ
Power Consumption	1000 W
Standby Power Consumption	6W
Dimensions	435 x 310x 45 mm
Height including feet	62mm
Weight	4.5 Kg

Specifications and features are subject to change without notice.

Acknowledgments – FreeRTOS – uIP

The AX-1255 firmware is based in part on FreeRTOS.org™ V10.2.0 and the uIP TCP/IP stack.

For more information on FreeRTOS.org™ please visit <http://www.freertos.org>.
Source code for FreeRTOS.org™ can be downloaded from their official website.

The following copyright and statements for uIP TCP/IP stack are required by license:
Copyright (c) 2001-2003, Adam Dunkels. All rights reserved.

Redistribution and use in source & binary forms, with or without modification, are permitted provided that the following conditions are met:

1. Redistributions of source code must retain the above copyright notice, this list of conditions and the following disclaimer.
2. Redistributions in binary form must reproduce the above copyright notice, this list of conditions and the following disclaimer in the documentation and/or other materials provided with the distribution.
3. The name of the author may not be used to endorse or promote products derived from this software without specific prior written permission.

THIS SOFTWARE IS PROVIDED BY THE AUTHOR "AS IS" AND ANY EXPRESS OR IMPLIED WARRANTIES, INCLUDING, BUT NOT LIMITED TO, THE IMPLIED WARRANTIES OF MERCHANTABILITY AND FITNESS FOR A PARTICULAR PURPOSE ARE DISCLAIMED. IN NO EVENT SHALL THE AUTHOR BE LIABLE FOR ANY DIRECT, INDIRECT, INCIDENTAL, SPECIAL, EXEMPLARY, OR CONSEQUENTIAL DAMAGES (INCLUDING, BUT NOT LIMITED TO, PROCUREMENT OF SUBSTITUTE GOODS

